

# EZ Fit™ Ball Lock Retainer Inserts

Inch & Metric



Dayton EZ Fit™ Ball Lock Retainer Inserts give you the ability to reconfigure and custom-make retainers in-house as die specifications change. The unique single-piece teardrop shape, combined with both a straight and an angled wedge side, holds your ball lock punch securely in place. EZ Fit™ Inserts reduce costs and downtime—and simplify tooling changeover.

## A Simpler, Better Way

Cost-effective.  
Innovative,  
New Design

# EZ Fit™ Inserts



Global leader in  
providing fabrication  
and stamping solutions

[www.daytonprogress.com](http://www.daytonprogress.com)

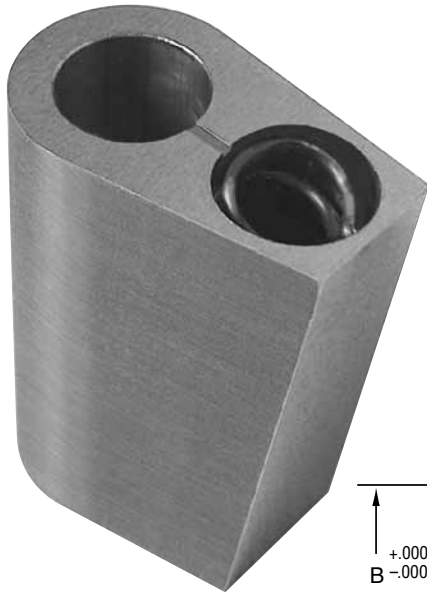

INCH

**HRI**  
Heavy Duty

**LRI**  
Light Duty

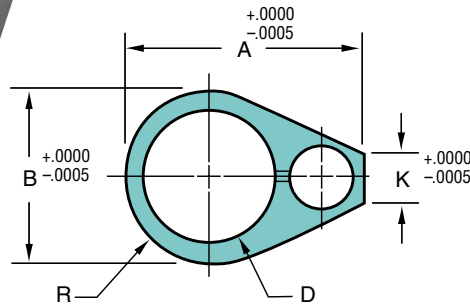

Ball hole location radial tolerance  $\pm 0^{\circ}5'$

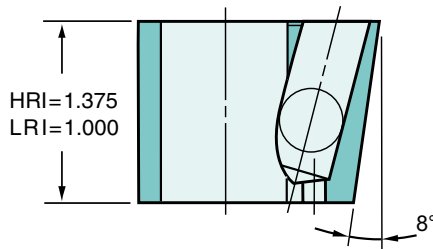

**Heavy Duty**

Type	Punch Hole Dia. D	Code	A	B	K
HRI	0.3750	37	1.0630	0.6250	0.3882
	0.5000	50	1.3190	0.7500	0.5250
	0.6250	62	1.4570	0.9000	0.4698
	0.7500	75	1.6040	1.0600	0.4202
	0.8750	87	1.7320	1.1950	0.4182
	1.0000	100	1.8700	1.3200	0.4111
	1.2500	125	2.1260	1.5700	0.3951

**Light Duty**

Type	Punch Hole Dia. D	Code	A	B	K
LRI	0.2500	25	0.7750	0.4375	0.3125
	0.3750	37	0.9000	0.5625	0.3125
	0.5000	50	1.1200	0.7500	0.3125
	0.6250	62	1.2500	0.8750	0.3125
	0.7500	75	1.4700	1.0700	0.3125
	0.8750	87	1.6000	1.1950	0.3125
	1.0000	100	1.7200	1.3200	0.3125

## Build New or Modify Existing Retainers—Quickly & Easily

Dayton EZ Fit™ Inserts provide a simple, low-cost solution to *building* new dies because the inserts utilize a revolutionary design that assures a positive, rigid, and more accurate fit than other inserts on the market.

One side of the insert is cut at an 8° angle to create a wedge shape that—when combined with the teardrop shape—assures that the insert and retainer fit together as a single unit. (See cutaway.)



EZ Fit™ Inserts are also ideal for *repairing or making engineering changes*. When changes occur—and the location(s) of the punches in the die set change(s)—new or reconfigured retainers are required. In-house modification can slow the changeover process; often requires specialized equipment and knowledge; and the integrity of the original retainer can be compromised.

Now—with the help of the all-new Dayton EZ Fit™ Ball Lock Retainer Insert—building new or repairing/retrofitting existing retainers can be simplified and completed in-house *at a fraction of the cost of replacing existing retainers!*



1 Day

**HOW TO ORDER**

Specify:	Qty.	Type	Code
Example:	5	HRI	37
	12	LRI	62



## In-house Modifications

Dayton EZ Fit™ Retainer Inserts can be used to change hole locations in Multi-Position™ Retainers, thus allowing reuse of existing retainers. The process is quick, easy, effective, and far less expensive than part replacement costs. To retrofit, simply wire cut the hole to the specified size. Wire cut EDM instructions included with each insert, and are available at [www.daytonprogress.com/EZFit](http://www.daytonprogress.com/EZFit)

## Tighter Tolerances. Optimum Performance.

Dayton EZ Fit™ Inserts are designed to assure tighter, more precise tolerances than other retainer inserts.

The EZ Fit™ unique teardrop shape provides a *single, tightly secured receptacle* for the punch. One side of the piece (the flat side) is cut at an 8° angle to create a wedge shape. The hole in the retainer is wire cut to create a snug fit.

## Wire Cut EDM

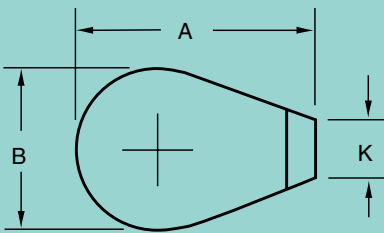

Each insert comes complete with wire cutting instructions that show recommended dimensions and tolerances for optimum performance. Wire cutting instructions are also available online at [www.daytonprogress.com/EZFit](http://www.daytonprogress.com/EZFit)

METRIC

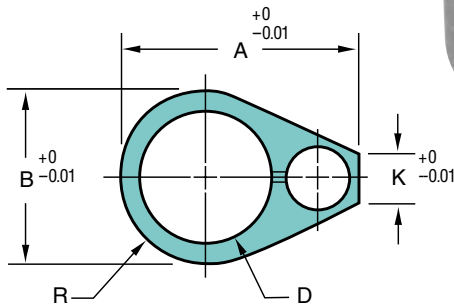

Ball hole location radial tolerance  $\pm 0^{\circ}5'$

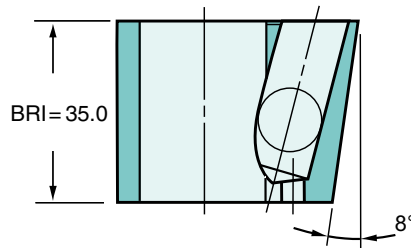

**BRI**  
Heavy Duty

### Heavy Duty

Type	Punch Hole Dia. D	Code	A	B	K
BRI	10	10	27.5	16.0	10.89
	13	13	33.0	19.5	12.26
	16	16	36.4	23.0	11.06
	20	20	40.7	27.5	9.88
	25	25	46.0	33.0	9.42
	32	32	53.2	40.0	8.92
	40	40	61.4	48.0	8.54

**FDS**  
FIRM DELIVERY SCHEDULE

1 Day

### HOW TO ORDER

Specify: Qty. Type Code  
Example: 5 BRI 13

Dayton Progress Corporation  
500 Progress Road  
P.O. Box 39  
Dayton, OH 45449-0039 USA

Dayton Progress Portland  
1314 Meridian St.  
Portland, IN 47371 USA

Dayton Progress Canada, Ltd.  
861 Rowntree Dairy Road  
Woodbridge, Ontario L4L 5W3

Dayton Progress Mexico, S. de R.L. de C.V.  
Access II Number 5, Warehouse 9  
Benito Juarez Industrial Park  
Querétaro, Qro. Mexico 76130

Dayton Progress, Ltd.  
G1 Holly Farm Business Park  
Honiley, Kenilworth  
Warwickshire CV8 1NP UK

Dayton Progress Corporation of Japan  
2-7-35 Hashimotodai, Midori-Ku  
Sagamihara-Shi, Kanagawa-Ken  
252-0132 Japan

Dayton Progress GmbH  
Adenauerallee 2  
61440 Oberursel/TS, Germany

Dayton Progress Perfuradores Lda  
Zona Industrial de Casal da Areia Lote 17  
Cós, 2460-392 Alcobaça, Portugal

Dayton Progress SAS  
105 Avenue de l'Épinette  
BP 128  
Zone Industrielle  
77107 Meaux Cedex, France

Dayton Progress Czech sro  
Hala G  
Pražská 707  
CZ-294 71 Benátky nad Jizerou  
Czech Republic



Global leader in providing fabrication and stamping solutions